

ARTICLE CODE
S27 2C DC12V

S27(JQX-59F) Series



Coil Voltage
6~110VDC
6~220VAC

Contact Ratings
1C,1A,1B

Model Name:S27

Main Features:

- With open type, dust-proof cover type.
- Flange mounting, screw terminal connecting wire.

PERFORMANCE(at initial value)

Item	Type	1C,1A,1B
Contact Resistance		100mΩ Max.(Initial Value)
Operate Time		25msec Max.
Release Time		25msec Max.
Pull In Voltage(VDC)		DC:75%Max,AC:80%Max
Drop Out Voltage(VDC)		DC:10%Max,AC:30%Max
Max. Allowable Voltage(VDC)		110%Max
Coil Nominal Voltage		DC:6V,9V,12V,24V,36V,48V,110V,220V AC:6V,9V,12V,24V,36V,48V,110V,220V
Power Consumption(W)		DC:3.6W AC:10.5VA
Dielectric Strength between Coil & Contact between Contact between Contact		2500VAC (1min) 1500VAC (1min) 1500VAC (1min)
Insulation Resistance		1000MΩ Min.(DC500V)
Operating Ambient Temperature		-40℃ ~+70℃
Humidity		35 to 80% RH
Rated Carrying Current		80A/250VAC 80A/30VDC
Vibration Resistance		10G(10~55Hz) (Dual Amplitude:1.0mm)
Shock Resistance		10G
Life Expectancy Mechanically Electrically		10,000,000 ops.Min.(18000 ops./h) 100,000 ops.Min.(1800 ops./h)
Weight		240g(approx.)

COIL RATING(at 20℃)

	Nominal Voltage (VDC)	Coil Resistance (Ω)(±10%)	Power Consumption(W)	Nominal Current (mA)(±10%)	Pull In Voltage (VDC)	Drop Out Voltage (VDC)	Max. Allowable Voltage (VDC)
DC	6V	10Ω	3.6W	600.0mA	75% MAX	10% MIX	110%
	12V	40Ω		300.0mA			
	24V	160Ω		150.0mA			
	48V	640Ω		75.0mA			
	60V	1000Ω		60.0mA			
	110V	3360Ω		32.7mA			

	Nominal Voltage (VAC)	Coil Resistance (Ω)(±10%)	Power Consumption(VA)	Pull In Voltage (VAC)	Drop Out Voltage (VAC)	Max. Allowable Voltage (VAC)
AC	6V	1.2Ω	10.5VA	80% MAX	30% MIX	110%
	9V	2.7Ω				
	12V	4.8Ω				
	18V	10.8Ω				
	24V	19.2Ω				
	48V	77Ω				
	110V	403Ω				
	220V	1620Ω				

OUTLINE DIMENSION, WIRING DIAGRAM & PC BOARD LAYOUT

Unit: mm

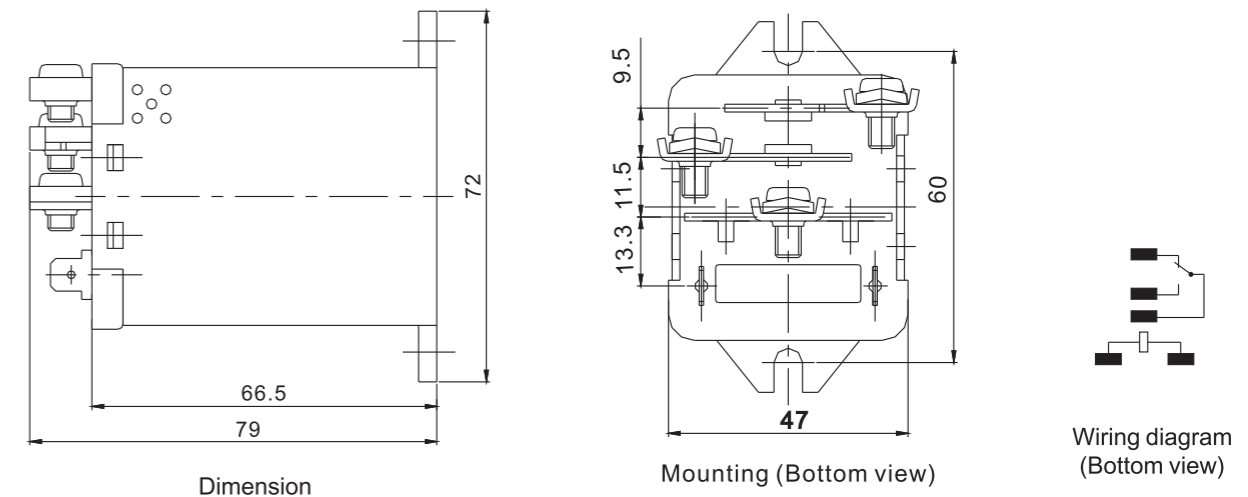

Remark: 1) In case of no tolerance shown in outline dimension: outline dimension ≤1mm, tolerance should be ±0.2mm; outline dimension >1mm and ≤5mm, tolerance should be ±0.3mm; outline dimension >5mm, tolerance should be ±0.4mm.
 2) The tolerance without indicating for PCB layout is always ±0.1mm.

WIRING DIAGRAMS(Bottom View)

