

ARTICLE CODE

S3 - 12 A T

Nil: Standard type
T: Volume of the Tall type

Nil: 1C
A: 1A
B: 1B

Coil Voltage
3,5,6,9,12,18,24,36,48VDC

Model Name: S3

S3 Series

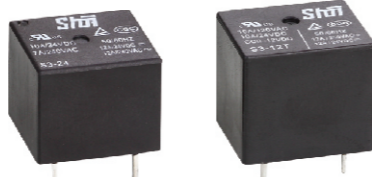

Main Features:

- UL, TUV, CQC safety approval
- Heavy current up to 15 amps available, and special 20amps for using on the car
- Epoxy seal type and flux free
- Satisfying all requirements for use in car and household electric appliances
- High operating temperature around Max. 105°C

COIL RATING(at 20°C)

Nominal voltage (VDC)	Coil Resistance (Ω)(±10%)		Power Consumption(W)	Nominal Current (mA)(±10%)		Pull In Voltage (VDC)	Drop Out Voltage (VDC)	Max. Allowable Voltage (VDC)
	0.36W	0.45W		0.36W	0.45W			
3V	25.0Ω	20.0Ω	0.36W&0.45W	120.0mA	150.0mA	75% MAX	10% MIX	130%
5V	70.0Ω	55.6Ω		72.0mA	90.0mA			
6V	100.0Ω	80.0Ω		60.0mA	90.0mA			
9V	225.0Ω	180.0Ω		40.0mA	50.0mA			
12V	400.0Ω	320.0Ω		30.0mA	37.5mA			
18V	900.0Ω	720.0Ω		20.0mA	25.0mA			
24V	1600.0Ω	1280.0Ω		15.0mA	18.8mA			
36V	3600.0Ω	2880.0Ω		10.0mA	12.5mA			
48V	6400.0Ω	5120.0Ω		7.5mA	9.5mA			

PERFORMANCE(at initial value)

Item	Type	12A	15A
Contact Resistance		100mΩ	Max.(Initial Value)
Operate Time		10msec Max.	
Release Time		5msec Max.	
Dielectric Strength between Coil & Contact between Contact		1500VAC(1min) 750VAC(1min)	
Insulation Resistance		100MΩ Min.(DC500V)	
Operating Ambient Temperature		-35°C ~ +85°C	-35°C ~ +105°C
Humidity		35 to 85% RH	
Vibration Resistance		10G(10~55Hz) (Dual Amplitude:1.5mm)	
Shock Resistance		10G	
Life Expectancy Mechanically Electrically		10,000,000 ops.Min.(1800 ops./h) 100,000 ops.Min.(1200 ops./h)	
Weight		S3:9g	S3-T:11g(approx.)

CONTACT RATING

Item	Type	12A	15A
Rated Carrying Current (Resistive)		AC 250V 12A DC 24V 12A	AC 125V 15A AC 240V 12A DC 24V 12A
Max. Allowable Current		15A	20A
Max. Allowable Voltage		AC 240V DC 110V	
Max. Current(Continual)		10A	15A
Contact Material		Ag alloy	

OUTLINE DIMENSION, WIRING DIAGRAM & PC BOARD LAYOUT

Unit: mm

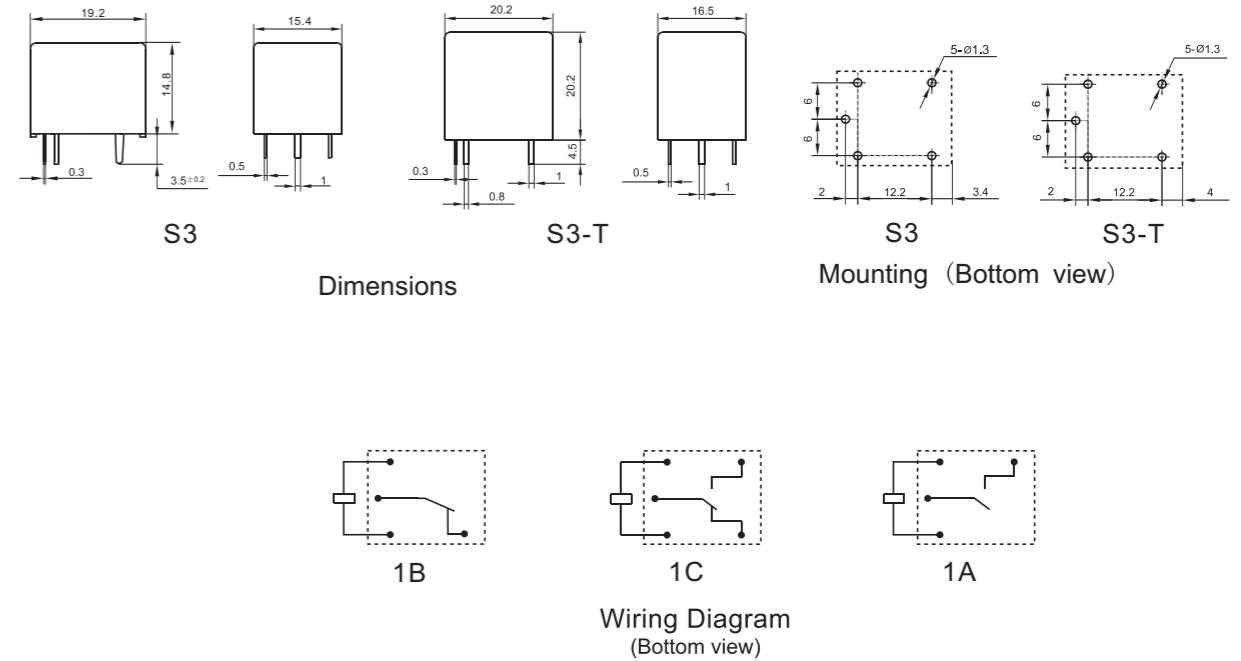

Remark: 1) In case of no tolerance shown in outline dimension: outline dimension ≤1mm, tolerance should be ±0.2mm; outline dimension >1mm and ≤5mm, tolerance should be ±0.3mm; outline dimension >5mm, tolerance should be ±0.4mm.
2) The tolerance without indicating for PCB layout is always ±0.1mm.

REFERENCE DATA

